



VF
VFH

Butterfly valves
DN40 ... DN200

VF

VFH

Butterfly valves

Contents

Description	2
Features	2
Functioning and application	3
Technical specifications	4
Flow chart (pressure drop)	7
Flow velocities chart	9
Flow factor K_{VS}	10
Ordering information	12
Standards and approvals	12

Description

VF and VFH butterfly valves are designed for regulation and control of gas flow and air flow in combustion processes.

Valves can be operated manually using a lever (to setup the high-fire rate of the burner) or automatically using a servomotor (modulating or staged control) or a solenoid actuator (two-stage control).

Features

Valves are made of aluminium casting (VF type) or cast-iron (VFH type), with wide range of connections from DN40 up to DN200.

Installation between EN 1092 flanges.

Possibility to have one-size or two-size reductions of the nominal diameter for VF type.

Suitable for use with air and non-aggressive gases according to EN 437 (VF type); heated air and flue gas (VFH type).

Low leakage when valve is in closed position (VFH type provided with butterfly disc stop).

The VFH type is provided with a double-eccentricity disc and a spring to reduce the backlash. This results in an high precision adjustment and avoids valve floating.

Operated by manual lever, servomotor or by solenoid actuator.

All components are designed to withstand any mechanical, chemical, thermal condition occurring during typical service. Effective impregnation and surface treatments have been used to improve mechanical sturdiness, sealing and resistance to corrosion of the components.



WARNING

This control must be installed in compliance with the rules in force.

Functioning and application

VF/VFH butterfly valves are devices for regulation/modulation using auxiliary power supply or manually operated.

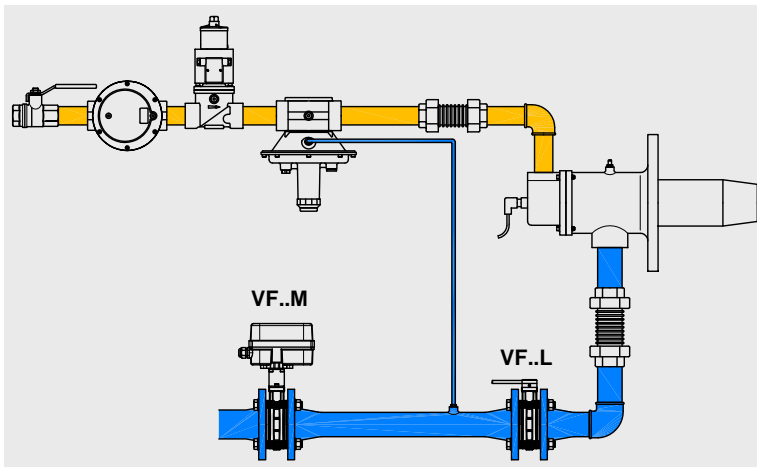

Fig. 1

- in case of combustion process being regulated by combustion air modulation, VF valves with servomotor can be used, coupled to another butterfly valve manually operated (available graduated scale and locking screw) to setup high-fire rate of the burner.

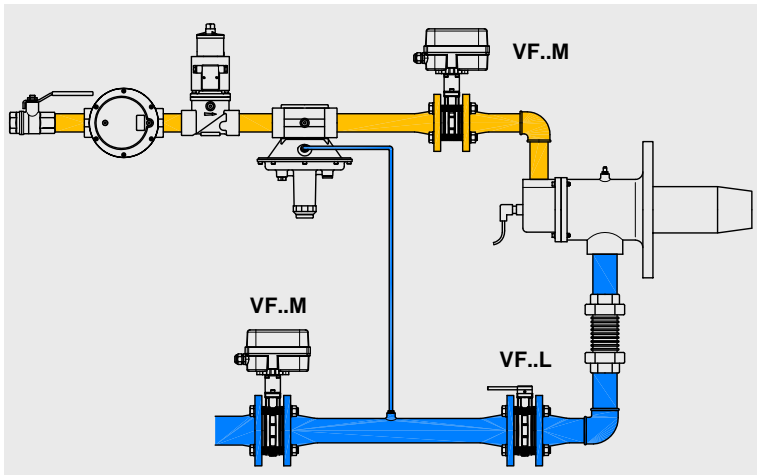

Fig. 2

- In case of combustion process with excess of air or gas, VF butterfly valve can be used, coupled to a Lambda sensor for ratio correction.

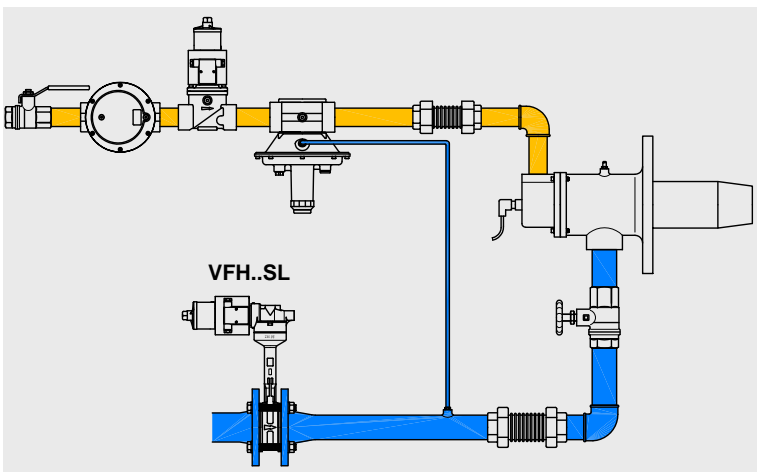

Fig. 3

- In case of combustion process with pre-heated air, VFH butterfly valve can be used. Solenoid actuator is preferentially suitable for min/max regulation with heavy duty cycles.



WARNING

Location and mode of installation must be in compliance with local rules in force.

Technical specifications

Tab. 1

	VF	VFH
Connections	From DN40 up to DN150 for fitting between two flanges according to EN 1092 PN16	From DN40 up to DN200 for fitting between two flanges according to EN 1092 PN16
Rotation angle	0 / 90° adjustable	0 / 90° adjustable
Ambient temperature	-15°C / +60°C	-15°C / +60°C
Media type	Air and non-aggressive gases according EN 437	Heated air and flue gas
Max. media temperature	+60°C +200°C for use with air only (special version on request)	+250°C +450°C with dissipators (optional kit)
Max. Operating pressure	500 mbar (50 kPa)	150 mbar (15 kPa)
Max. Pressure loss @ V_{max}	150 mbar (15 kPa)	45 mbar (4,5 kPa)
Flow rate	See tables	See tables
Materials in contact with fluid	Aluminium alloy Copper alloy Stainless steel Nitrile rubber (NBR) Fluoro elastomer (FPM) Polytetrafluoroethylene (PTFE)	Cast iron Stainless steel Polytetrafluoroethylene (PTFE)
Driving systems and actuators	- square shaft □8 - round shaft Ø10 - manual lever - solenoid SR/SL/ST - servomotor MZ	- manual lever - solenoid SR/SL/ST - servomotor MZ

VF	DN40	DN50	DN65	DN80	DN100	DN125	DN150	
MZ	●	●	●	●	●	●	●	
S..4	●	●	●					
S..8				●	●	●	●	

VFH	DN40	DN50	DN65	DN80	DN100	DN125	DN150	DN200
MZ	●	●	●	●	●	●	●	●
S..4	●	●						
S..8			●	●	●			

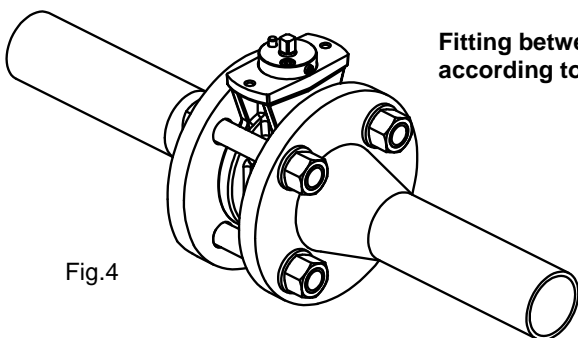

Fitting between two flanges according to EN 1092 PN16

Fig.4

VF

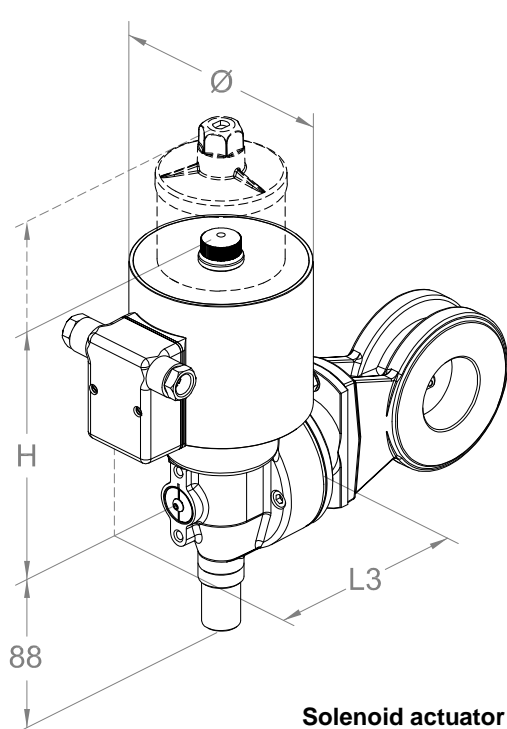
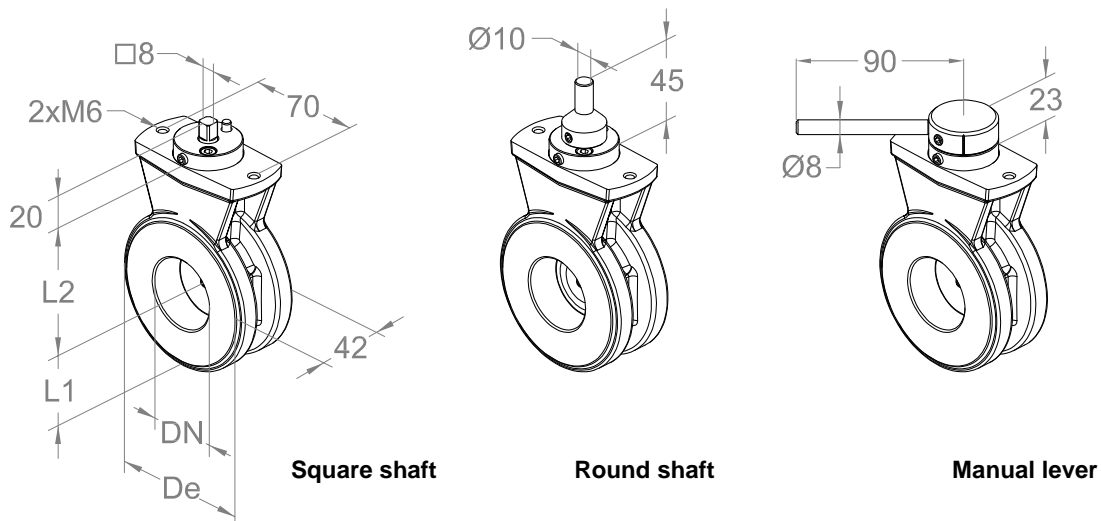

Solenoid actuator

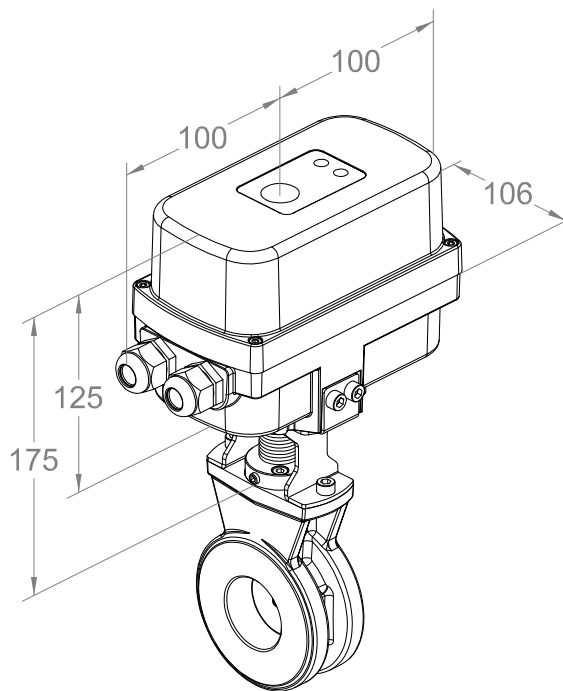

Servomotor

Fig.5

Tab. 2

Connections	Overall dimensions [mm]			Weight ⁽¹⁾ [Kg]	Actuator	Overall dimensions [mm]			Weight [Kg]
	De	L1	L2			L3	H	Ø	
DN 40	92	46	80	0,8	SR4	126	160	100	5,0
DN 50	107	53,5	87,5	0,9	SL4	126	230	100	5,5
DN 65	127	63,5	97,5	1,2	ST4	126	240	100	5,6
DN 80	142	71	105	1,3	SR8	134	182	114	7,2
DN 100	162	81	115	1,5	SL8	134	252	114	7,7
DN 125	192	96	130	1,8	ST8	134	262	114	7,8
DN 150	217	108,5	147,5	2,2	MZ				2,0

⁽¹⁾ Actuator weight excluded (adapter for VF..S 0,55Kg)

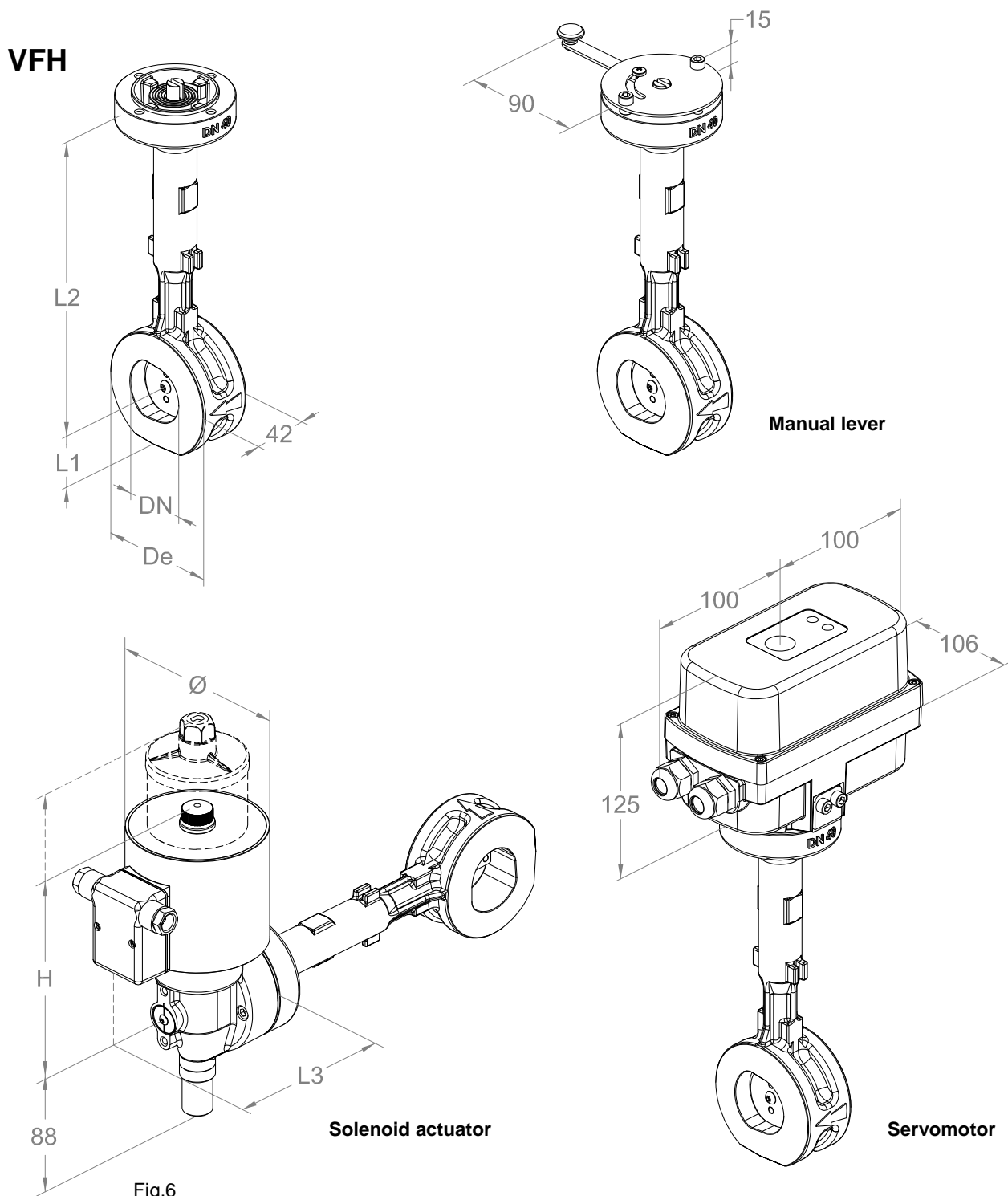

Fig.6

Tab. 3

Connections	Overall dimensions [mm]			Weight ⁽¹⁾ [Kg]	Actuator	Overall dimensions [mm]			Weight [Kg]
	De	L1	L2			L3	H	Ø	
DN 40	92	42	230	2,9	SR4	126	160	100	5,0
DN 50	107	49,5	237,5	3,3	SL4	126	230	100	5,5
DN 65	127	59,5	247,5	3,9	ST4	126	240	100	5,6
DN 80	142	67	255	4,3	SR8	134	182	114	7,2
DN 100	162	81	265	4,8	SL8	134	252	114	7,7
DN 125	192	99	275	7,2	ST8	134	262	114	7,8
DN 150	217	111	287	8,2	MZ				2,0
DN 200	275	140	315	11					

⁽¹⁾ Actuator weight excluded

Flow chart - VF

- blue lines: leakage @ 0° opening angle
- orange lines: max flowrate @ 90° opening angle

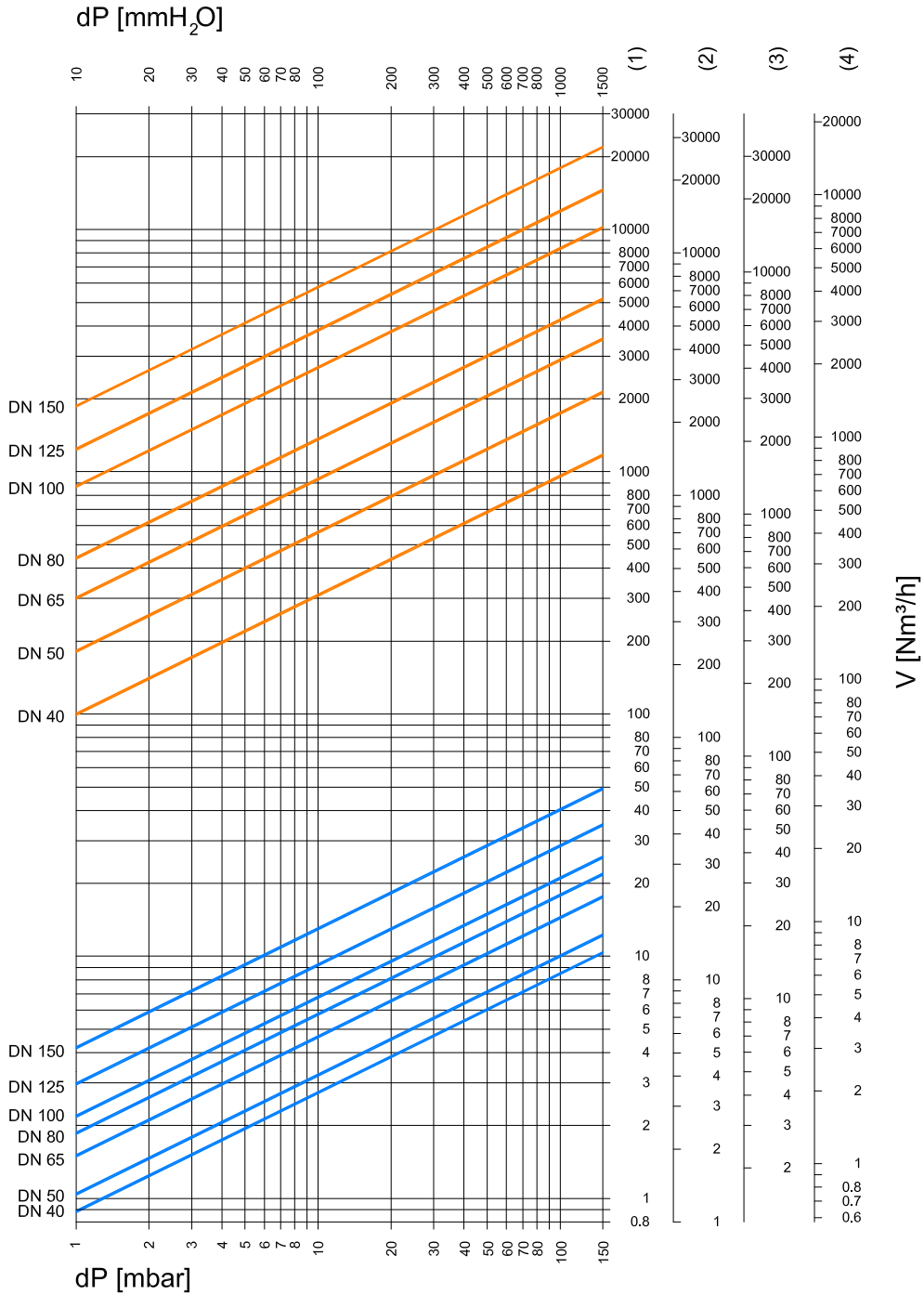

Fig.7

Formula of conversion from air to other gases

$$V_{GAS} = k \cdot V_{AIR}$$

Tab. 4

Gas type	Specific gravity ρ [Kg/m ³]	$k = \sqrt{\frac{1,25}{\rho_{GAS}}}$
1) Air	1,25	1,00
2) Natural gas	0,80	1,25
3) Town gas	0,57	1,48
4) LPG	2,08	0,77

15°C, 1013 mbar, dry

Flow chart - VFH

- blue lines: leakage @ 0° opening angle
- orange lines: max flowrate @ 90° opening angle

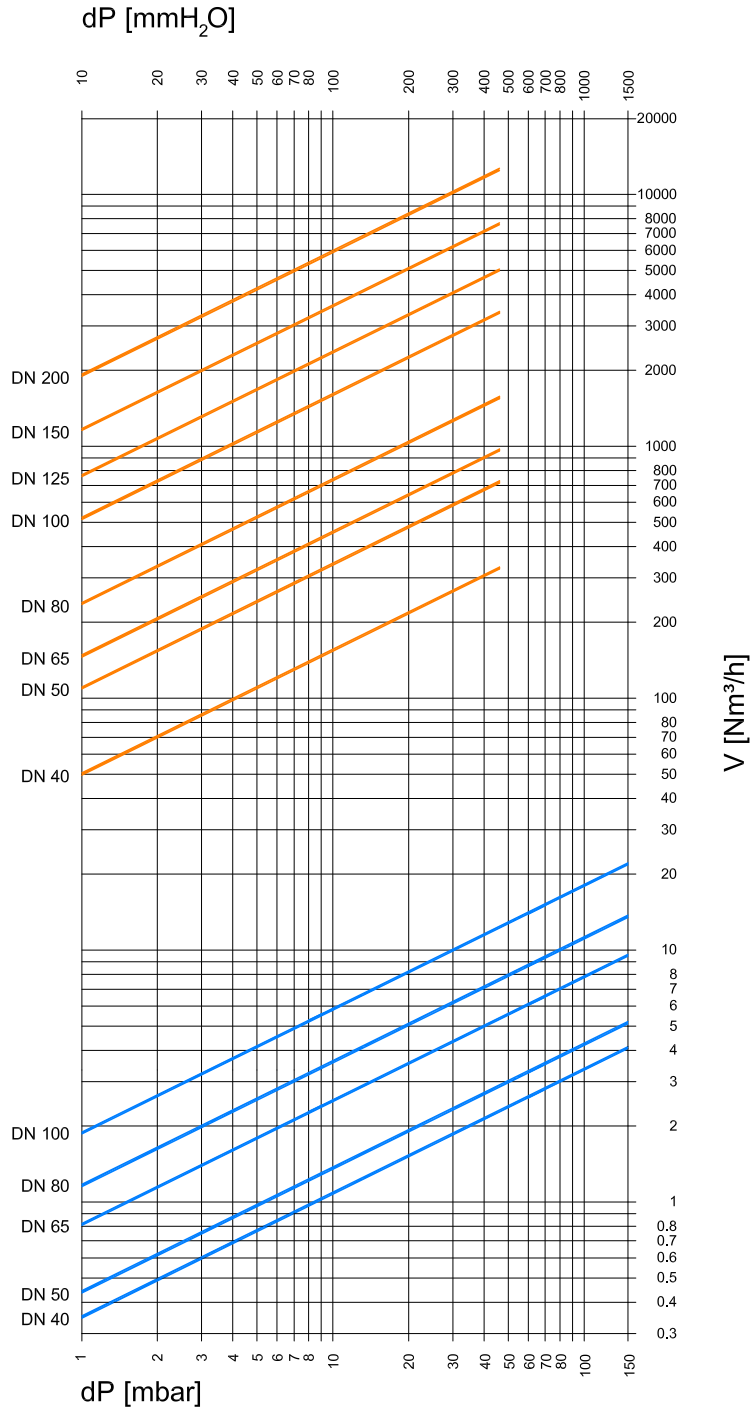

Fig.8



Pressure drop (Δp) being 30% of inlet pressure p_1 assures a good flow control.

Flow velocities chart

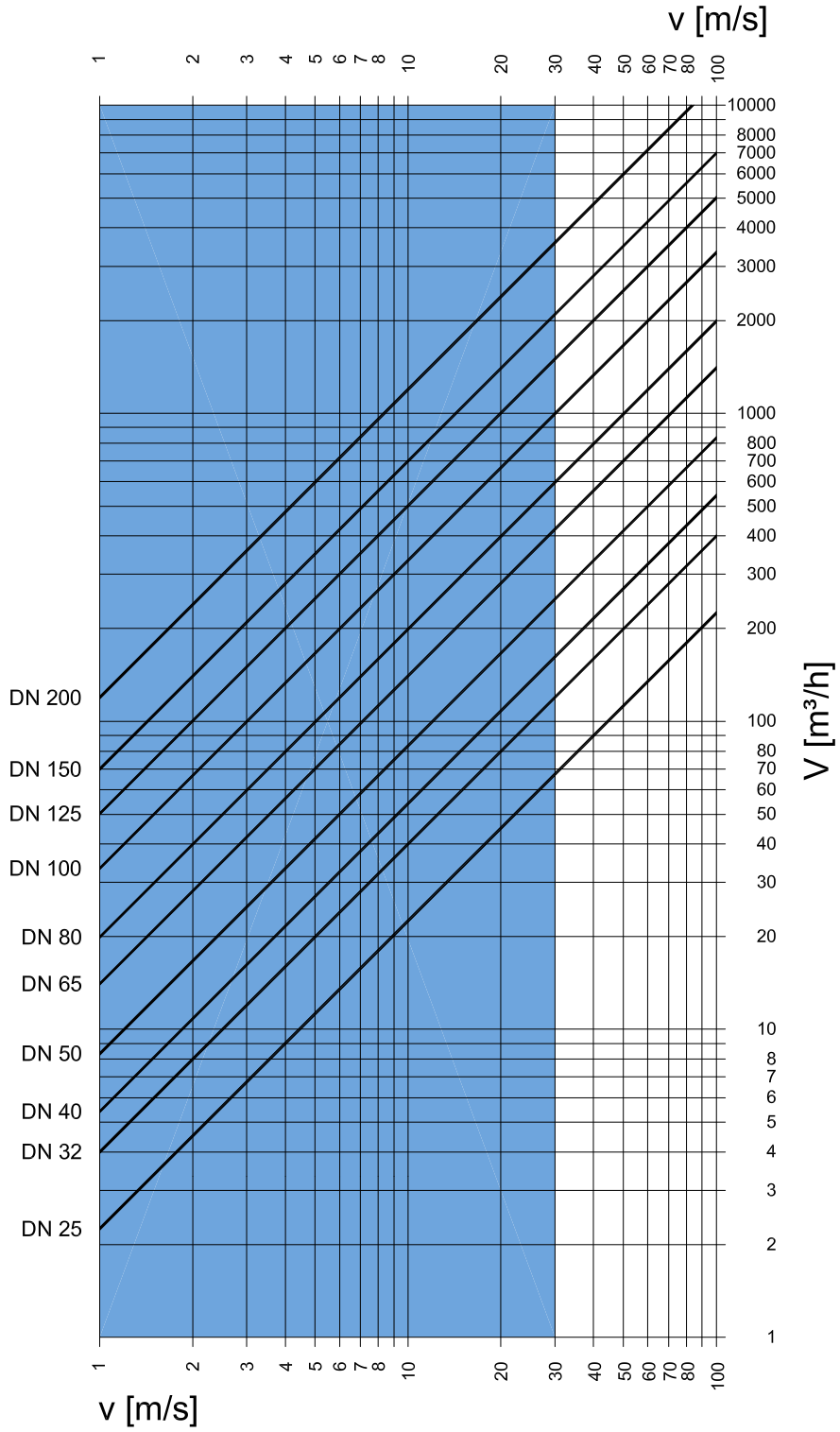

Fig.9



Flow velocity lower than 30 m/s is recommended to avoid noise and turbulence that can affect pressure drop.

Flow factor K_{Vs}

(15°C, 1013 mbar, dry)

VF type

Tab. 5

Connection	Reduction	Opening angle									
		0°	10°	20°	30°	40°	50°	60°	70°	80°	90°
DN 40	DN 25	1.3	1.3	2.2	3.9	6.6	11	16	20	24	27
	DN 32	1.2	1.4	2.8	5.4	9.5	16	27	41	57	63
	DN 40	1.0	1.5	3.6	7.3	13	23	37	56	77	90
DN 50	DN 32	1.2	1.4	2.8	5.4	9.6	16	26	38	50	56
	DN 40	1.1	1.5	3.2	7.1	13	21	34	52	73	90
	DN 50	1.2	1.6	4.0	9.3	17	31	51	82	123	167
DN 65	DN 40	1.1	1.5	3.3	7.1	13	20	32	46	61	71
	DN 50	1.3	1.6	4.3	9.5	17	29	46	68	97	120
	DN 65	1.7	2.7	7.3	16	32	57	94	144	210	281
DN 80	DN 50	1.3	1.6	4.0	9.0	16	28	44	64	85	101
	DN 65	2.0	2.4	7.0	16	31	55	89	132	185	243
	DN 80	2.1	3.2	9.8	24	47	83	132	202	296	405
DN 100	DN 65	2.0	2.9	7.7	17	32	55	86	122	162	185
	DN 80	2.4	3.3	9.8	23	49	88	140	203	275	335
	DN 100	2.5	3.4	12	33	59	133	214	331	517	792
DN 125	DN 80	2.4	3.4	8.7	22	47	85	133	185	237	273
	DN 100	2.9	5.2	17	48	103	173	262	364	478	561
	DN 125	3.4	7.4	25	78	145	244	385	583	910	1132
DN 150	DN 100	2.9	4.2	15	42	95	160	237	319	397	458
	DN 125	3.8	6.6	25	89	180	288	422	586	771	940
	DN 150	4.7	13	58	132	229	369	583	882	1557	1696

VFH type

Tab. 6

Connection	Opening angle									
	0°	10°	20°	30°	40°	50°	60°	70°	80°	90°
DN 40	0.4	6.5	10	13	17	23	31	42	55	60
DN 50	0.5	10	14	18	25	36	51	75	108	120
DN 65	0.9	15	23	31	44	64	85	114	150	160
DN 80	1.3	24	35	46	63	96	137	190	243	260
DN 100	2.1	34	52	74	105	165	250	370	540	570
DN 125	See diagram									
DN 150										
DN 200										

Valve dimension can be calculated using flow diagrams or using characteristic flow factor (K_{Vs}) mentioned in tables 5 and 6 for several opening angles of the butterfly disc.

Example (calculation using diagram):

Target is to select a valve for air with $p_2 = 50$ mbar and flow rate $V = 800$ Nm³/h. DN100 pipes are advisable to avoid to overtake recommended flow velocity.
Pressure drop will be:

$$\Delta p = \left(\frac{0.3}{1-0.3} \right) p_2 = 21.4 \text{ mbar}$$

VF diagram curves suggest that DN65 valve can assure the requested flow rate. Considering DN100 pipe diameter, version DN100/65 (double reduction) can be adopted.

Example (calculation using flow factor K_{VS}):

Target is to select a valve for air at 250°C temperature with $p_2 = 30$ mbar and flow rate $V_{MAX} = 200$ Nm³/h. DN50 pipes are advisable to avoid to overtake recommended gas speed.
Pressure drop will be:

$$\Delta p = \left(\frac{0.3}{1-0.3} \right) p_2 \cong 13 \text{ mbar}$$

Valve identification requires the calculation of K_V factor under operating conditions. Considering subcritical pressure drops only:

$$\Delta p < \frac{p_1}{2}$$

K_V can be calculated with the formula:

$$K_V = \frac{V}{514} \sqrt{\frac{\rho(t+273)}{\Delta p \cdot p_{2A}}}$$

where:

- V = flow rate [Nm³/h]
- K_V = flow factor [m³/h]
- ρ = density [Kg/m³]
- p_{1A} = absolute inlet pressure [bar]
- p_{2A} = absolute outlet pressure [bar]
- Δp = differential pressure $p_1 - p_2$ [bar]
- t = media temperature [°C]

$$K_V = \frac{200}{514} \sqrt{\frac{1.25(250+273)}{0.013 \cdot 1.043}} \cong 85$$

VFH valve (type for heated air) having K_{VS} just higher than K_V is DN 50 (table 6).

Considering a linear K_V behavior with opening angle, the required K_V value comes with an angle of about 72°.

Using the following formula it is now possible to determine the leakage rate with completely closed disc or the flow rate V_{MIN} with disc in minimum flow rate setting:

$$V = 514 \cdot K_V \cdot \sqrt{\frac{\Delta p \cdot p_{2A}}{\rho(t+273)}}$$

Ordering information

Tab.7

VF	VFH	Type	VF	VFH	4	7	1	R
Connection								
●	●	4= DN40						
●	●	6= DN50						
●	●	7= DN65						
●	●	8= DN80						
●	●	9= DN100						
●	●	93= DN125						
●	●	95= DN150						
⊗	●	98= DN200						
Reduction DN								
●	●	= none						
○	⊗	1= 1xDN						
○	⊗	2= 2xDN						
Max. Media temperature								
●	⊗	= +60°C						
○	⊗	R= +200°C (air only)						
⊗	●	= +250°C (+450°C with dissipators)						
Driving systems and actuators								
●	⊗	- square shaft □8						
○	⊗	- round shaft Ø10						
○	○	- manual lever						
○	●	- solenoid SR/SL/ST						
○	○	- servomotor MZ						

For more information about actuators see their technical sheets.

● Standard ○ Optional ⊗ Not available



Manufacturer reserves the right to update or make technical changes without prior notice.

Standards and approvals



The VF valve type meets current European approval requirements regarding safety use on gaseous fuels. These products conform with the Gas Appliances Directive 2009/142/EC and the tests have been carried out according to EN13611 standard.

The certification has been issued by the notified body:

KIWA NEDERLAND B.V.
 Wilmersdorf, 50
 NL-7300 AC Apeldoorn
 CE Reg.-Nr. 0063CL1111

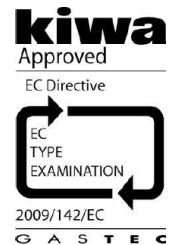

Quality Management System is certified according to UNI EN ISO 9001 and the monitoring is carried out by the notified body:

Kiwa Gastec Italia Spa
 Via Treviso, 32/34
 I- 31020 San Vendemiano (TV)

